

Data Sheet

Linha Sanitária

Conexões Tubulares



Redução concêntrica - solda

reducer-DIN-welding ends

| DN | Art. -Nr. | A | B | C | G (Kg) |
|-----------------|-----------|------|------|-------|--------|
| 1 1/2" / 1" | 322Z | 35,1 | 22,4 | 44,5 | 0,03 |
| 2" / 1" | " | 47,8 | 22,4 | 82,0 | 0,08 |
| 2" / 1 1/2" | " | 47,8 | 35,1 | 41,0 | 0,09 |
| 2 1/2" / 1" | " | 60,5 | 22,4 | 115,0 | 0,13 |
| 2 1/2" / 1 1/2" | " | 60,5 | 35,1 | 80,0 | 0,11 |
| 2 1/2" / 2" | " | 60,5 | 47,8 | 42,0 | 0,09 |
| 3" / 1" | " | 73,1 | 22,4 | 164,5 | 0,20 |
| 3" / 1 1/2" | " | 73,1 | 35,1 | 120,0 | 0,16 |
| 3" / 2" | " | 73,1 | 47,8 | 80,0 | 0,12 |
| 3" / 2 1/2" | " | 73,1 | 60,5 | 42,5 | 0,11 |
| 4" / 1" | " | 97,6 | 22,4 | 237,0 | 0,37 |
| 4" / 1 1/2" | " | 97,6 | 35,1 | 195,0 | 0,32 |
| 4" / 2" | " | 97,6 | 47,8 | 153,7 | 0,29 |
| 4" / 2 1/2" | " | 97,6 | 60,5 | 117,0 | 0,24 |
| 4" / 3" | " | 97,6 | 73,1 | 75,0 | 0,17 |

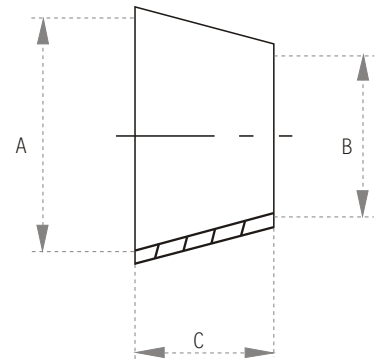
Índice
Redução excêntrica - solda

reducer-inch-welding ends-exc.

| DN | Art. -Nr. | A | B | C | G (Kg) |
|-----------------|-----------|------|------|-------|--------|
| 1 1/2" / 1" | 322ex | 35,1 | 22,4 | 44,5 | 0,03 |
| 2" / 1" | " | 47,8 | 22,4 | 82,0 | 0,08 |
| 2" / 1 1/2" | " | 47,8 | 35,1 | 41,0 | 0,09 |
| 2 1/2" / 1" | " | 60,5 | 22,4 | 115,0 | 0,13 |
| 2 1/2" / 1 1/2" | " | 60,5 | 35,1 | 80,0 | 0,11 |
| 2 1/2" / 2" | " | 60,5 | 47,8 | 42,0 | 0,09 |
| 3" / 1" | " | 73,1 | 22,4 | 164,5 | 0,20 |
| 3" / 1 1/2" | " | 73,1 | 35,1 | 120,0 | 0,16 |
| 3" / 2" | " | 73,1 | 47,8 | 80,0 | 0,12 |
| 3" / 2 1/2" | " | 73,1 | 60,5 | 42,5 | 0,11 |
| 4" / 1" | " | 97,6 | 22,4 | 237,0 | 0,37 |
| 4" / 1 1/2" | " | 97,6 | 35,1 | 195,0 | 0,32 |
| 4" / 2" | " | 97,6 | 47,8 | 153,7 | 0,29 |
| 4" / 2 1/2" | " | 97,6 | 60,5 | 117,0 | 0,24 |
| 4" / 3" | " | 97,6 | 73,1 | 75,0 | 0,17 |

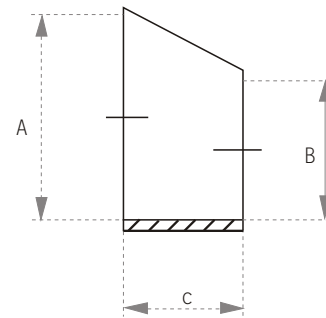
Índice
Redução concêntrica - clamp / clamp

reducer-inch-CC

| DN | Art. -Nr. | A | B | C | G (Kg) |
|-----------------|-----------|------|------|-------|--------|
| 1 1/2" / 1" | 344Z | 35,1 | 22,4 | 69,9 | 0,17 |
| 2" / 1" | " | 47,8 | 22,4 | 70,4 | 0,22 |
| 2" / 1 1/2" | " | 47,8 | 35,1 | 48,4 | 0,23 |
| 2 1/2" / 1" | " | 60,5 | 22,4 | 94,4 | 0,30 |
| 2 1/2" / 1 1/2" | " | 60,5 | 35,1 | 70,9 | 0,28 |
| 2 1/2" / 2" | " | 60,5 | 47,8 | 48,4 | 0,26 |
| 3" / 1" | " | 73,1 | 22,4 | 114,4 | 0,40 |
| 3" / 1 1/2" | " | 73,1 | 35,1 | 92,4 | 0,38 |
| 3" / 2" | " | 73,1 | 47,8 | 69,4 | 0,34 |
| 3" / 2 1/2" | " | 73,1 | 60,5 | 46,4 | 0,38 |
| 4" / 1" | " | 97,6 | 22,4 | 160,4 | 0,66 |
| 4" / 1 1/2" | " | 97,6 | 35,1 | 138,4 | 0,61 |
| 4" / 2" | " | 97,6 | 47,8 | 115,4 | 0,58 |
| 4" / 2 1/2" | " | 97,6 | 60,5 | 92,4 | 0,56 |
| 4" / 3" | " | 97,6 | 73,1 | 71,4 | 0,56 |

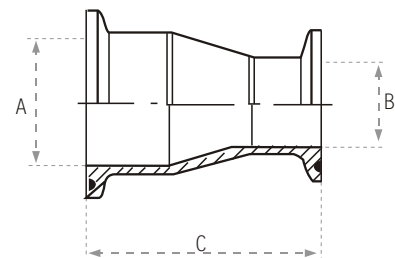
Índice

Relacionado com os artigos

285Z 288Z

Redução excêntrica - clamp / clamp

reducer-DIN-CC-exc.

| DN | Art.-Nr. | A | C | D | G (Kg) |
|-----------------|----------|------|------|-------|--------|
| 1 1/2" / 1" | 344ex | 35,1 | 22,4 | 69,9 | 0,17 |
| 2" / 1" | " | 47,8 | 22,4 | 70,4 | 0,22 |
| 2" / 1 1/2" | " | 47,8 | 35,1 | 48,4 | 0,23 |
| 2 1/2" / 1" | " | 60,5 | 22,4 | 94,4 | 0,30 |
| 2 1/2" / 1 1/2" | " | 60,5 | 35,1 | 70,9 | 0,28 |
| 2 1/2" / 2" | " | 60,5 | 47,8 | 48,4 | 0,26 |
| 3" / 1" | " | 73,1 | 22,4 | 114,4 | 0,40 |
| 3" / 1 1/2" | " | 73,1 | 35,1 | 92,4 | 0,38 |
| 3" / 2" | " | 73,1 | 47,8 | 69,4 | 0,34 |
| 3" / 2 1/2" | " | 73,1 | 60,5 | 46,4 | 0,38 |
| 4" / 1" | " | 97,6 | 22,4 | 160,4 | 0,66 |
| 4" / 1 1/2" | " | 97,6 | 35,1 | 138,4 | 0,61 |
| 4" / 2" | " | 97,6 | 47,8 | 115,4 | 0,58 |
| 4" / 2 1/2" | " | 97,6 | 60,5 | 92,4 | 0,56 |
| 4" / 3" | " | 97,6 | 73,1 | 71,4 | 0,56 |

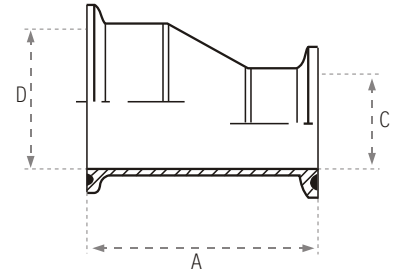

Índice

Relacionado com os artigos

285Z 288Z
Redução concêntrica - macho / macho DIN

reducer-DIN-male ends

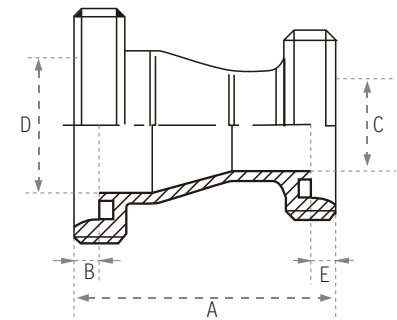
| DN | Art.-Nr. | A | B | C | D | E | G (Kg) |
|-----------------|----------|-------|----|------|------|---|--------|
| 1 1/2" / 1" | 355 | 106,5 | 7 | 22,4 | 35,1 | 7 | 0,38 |
| 2" / 1 1/2" | " | 109,9 | 7 | 35,1 | 47,8 | 7 | 0,58 |
| 2 1/2" / 1 1/2" | " | 153,0 | 8 | 35,1 | 60,5 | 7 | 0,60 |
| 2 1/2" / 2" | " | 117,0 | 8 | 47,8 | 60,5 | 7 | 0,84 |
| 3" / 2" | " | 160,0 | 8 | 47,8 | 73,1 | 7 | 0,91 |
| 3" / 2 1/2" | " | 127,5 | 8 | 60,5 | 73,1 | 8 | 1,03 |
| 4" / 2 1/2" | " | 211,0 | 10 | 60,5 | 97,6 | 8 | 1,73 |
| 4" / 3" | " | 174,0 | 10 | 73,1 | 97,6 | 8 | 1,70 |



Índice

Relacionado com os artigos

212D 213D
Redução concêntrica - macho / niple + porca DIN

reducer-DIN-male/liner

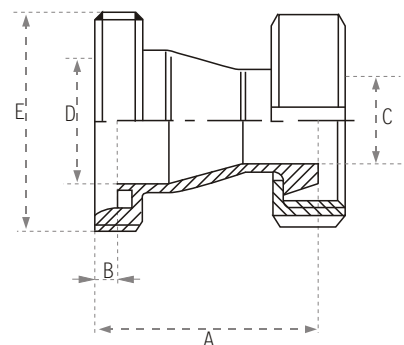
| DN | Art.-Nr. | A | B | C | D | E | G (Kg) |
|-----------------|----------|-------|----|------|------|----------|--------|
| 1 1/2" x 1" | 356 | 99,5 | 7 | 22,4 | 35,1 | 65x1/6" | 0,45 |
| 2" x 1 1/2" | 356 | 102,0 | 7 | 35,1 | 47,8 | 78x1/6" | 0,64 |
| 2 1/2" x 1 1/2" | 356 | 145,5 | 8 | 35,1 | 60,5 | 95x1/6" | 0,73 |
| 2 1/2" x 2" | 356 | 109,5 | 8 | 47,8 | 60,5 | 95x1/6" | 0,87 |
| 3" x 2" | 356 | 152,5 | 8 | 47,8 | 73,1 | 110x1/4" | 1,05 |
| 3" x 2 1/2" | 356 | 119,5 | 8 | 60,5 | 73,1 | 110x1/4" | 1,35 |
| 4" x 2 1/2" | 356 | 202,0 | 10 | 60,5 | 97,6 | 130x1/4" | 1,43 |
| 4" x 3" | 356 | 165,0 | 10 | 73,1 | 97,6 | 130x1/4" | 1,10 |

Índice

Relacionado com os artigos

212D 213D 214D 210

Redução concêntrica - niple + porca / macho DIN

reducer-DIN-liner/male

| DN | Art. -Nr. | A | B | C | D | E | G (Kg) |
|-----------|-----------|-------|---|------|------|----------|--------|
| 1½" x 1" | 365 | 99,5 | 7 | 22,4 | 35,1 | 52x1/6" | 0,50 |
| 2" x 1½" | 365 | 102,0 | 7 | 35,1 | 47,8 | 65x1/6" | 0,85 |
| 2½" x 1½" | 365 | 145,5 | 7 | 35,1 | 60,5 | 65x1/6" | 1,00 |
| 2½" x 2" | 365 | 109,5 | 7 | 47,8 | 60,5 | 78x1/6" | 1,05 |
| 3" x 2" | 365 | 152,5 | 7 | 47,8 | 73,1 | 78x1/6" | 1,15 |
| 3" x 2½" | 365 | 119,5 | 8 | 60,5 | 73,1 | 95x1/6" | 1,50 |
| 4" x 2½" | 365 | 202,0 | 8 | 60,5 | 97,6 | 95x1/6" | 1,92 |
| 4" x 3" | 365 | 165,0 | 8 | 73,1 | 97,6 | 110x1/4" | 1,95 |

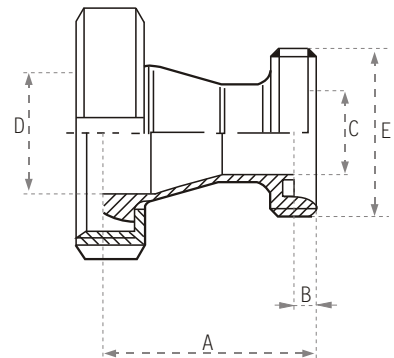
 Relacionado com os artigos [212D](#) [213D](#) [214D](#) [210](#)
[Índice](#)
Redução concêntrica - niple + porca / niple + porca DIN

reducer-DIN-liner/liner

| DN | Art. -Nr. | A | B | C | D | E | G (Kg) |
|-----------|-----------|-------|------|------|---|---|--------|
| 1½" x 1" | 366 | 92,5 | 35,1 | 22,4 | | | 0,71 |
| 2" x 1½" | 366 | 95,0 | 47,8 | 35,1 | | | 1,03 |
| 2½" x 1½" | 366 | 138,0 | 60,5 | 35,1 | | | 1,50 |
| 2½" x 2" | 366 | 102,0 | 60,5 | 47,8 | | | 1,56 |
| 3" x 2" | 366 | 145,0 | 73,1 | 47,8 | | | 1,65 |
| 3" x 2½" | 366 | 111,5 | 73,1 | 60,5 | | | 1,97 |
| 4" x 2½" | 366 | 193,0 | 97,6 | 60,5 | | | 2,00 |
| 4" x 3" | 366 | 156,0 | 97,6 | 73,1 | | | 2,42 |

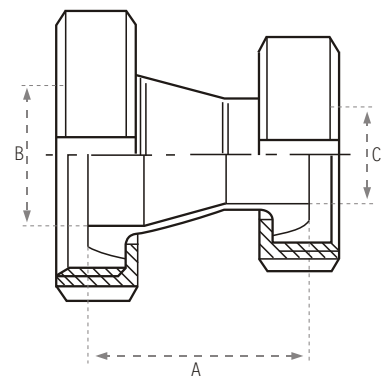
 Relacionado com os artigos [212D](#) [213D](#) [214D](#) [210](#)
[Índice](#)
Curva 90° - polegada OD - solda

bend 90 degree-inch-welding ends

| DN | Art. -Nr. | A | B | C | D | E | G (Kg) |
|-----|-----------|-------|-------|-------|-------|-----|--------|
| 1" | 422Z | 38,1 | 22,4 | 25,4 | 38,1 | 1,5 | 0,05 |
| 1½" | " | 57,2 | 35,1 | 38,1 | 57,2 | 1,5 | 0,10 |
| 2" | " | 76,2 | 47,8 | 50,8 | 76,2 | 1,5 | 0,20 |
| 2½" | " | 95,3 | 59,5 | 63,5 | 95,3 | 2,0 | 0,40 |
| 3" | " | 114,3 | 72,2 | 76,2 | 114,3 | 2,0 | 0,61 |
| 4" | " | 152,4 | 97,6 | 101,6 | 152,4 | 2,0 | 1,04 |
| 5" | " | 186,0 | 123,0 | 127,0 | 186,0 | 2,0 | 1,90 |
| 6" | " | 222,6 | 148,4 | 152,4 | 222,6 | 2,0 | 2,72 |
| 8" | " | 298,8 | 199,2 | 203,2 | 298,8 | 2,0 | 4,75 |
| 10" | " | 375,0 | 250,0 | 254,0 | 375,0 | 2,0 | 7,50 |

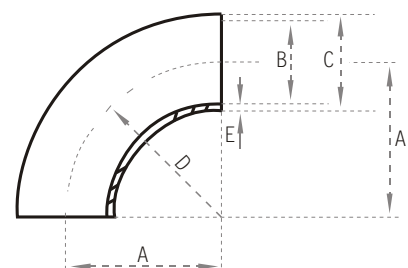
[Índice](#)

Curva 45° - polegada OD - solda

bend 45 degree-inch-welding ends

| DN | Art.-Nr. | A | B | C | D | E | G (Kg) |
|-----|----------|-------|-------|-------|-------|-----|--------|
| 1" | 422 A | 26,9 | 22,4 | 25,4 | 38,1 | 1,5 | 0,025 |
| 1½" | " | 40,4 | 35,1 | 38,1 | 57,2 | 1,5 | 0,05 |
| 2" | " | 53,5 | 47,8 | 50,8 | 76,2 | 1,5 | 0,10 |
| 2½" | " | 67,4 | 59,5 | 63,5 | 95,3 | 2,0 | 0,20 |
| 3" | " | 80,8 | 72,2 | 76,2 | 114,3 | 2,0 | 0,305 |
| 4" | " | 107,8 | 97,6 | 101,6 | 152,4 | 2,0 | 0,52 |
| 5" | " | 131,5 | 123,0 | 127,0 | 186,0 | 2,0 | 0,80 |
| 6" | " | 157,4 | 148,4 | 152,4 | 222,6 | 2,0 | 1,36 |
| 8" | " | 211,3 | 199,2 | 203,2 | 298,8 | 2,0 | 2,37 |
| 10" | " | 265,2 | 250,0 | 254,0 | 375,0 | 2,0 | 3,75 |

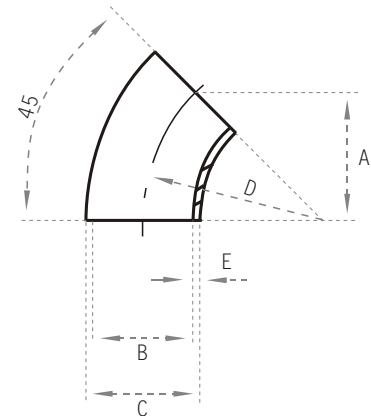
Índice
Curva 90°- polegada OD - macho / macho DIN

bend 90 degree-inch-male/male DIN

| DN | Art.-Nr. | A | B | C | D | E | G(Kg) |
|-------|----------|-------|----|-------|-------|---------|-------|
| Rosca | | | | | | | |
| 1" | 455 | 67,1 | 7 | 22,4 | 38,1 | 52X1/6 | 0,25 |
| 1½" | " | 90,2 | 7 | 35,1 | 57,2 | 65X1/6 | 0,40 |
| 2" | " | 111,2 | 7 | 47,8 | 76,2 | 78X1/6 | 0,50 |
| 2½" | " | 135,3 | 8 | 59,5 | 95,3 | 95X1/6 | 0,90 |
| 3" | " | 154,3 | 8 | 72,2 | 114,3 | 110X1/4 | 1,38 |
| 4" | " | 206,4 | 10 | 97,6 | 152,4 | 130X1/4 | 2,32 |
| 5" | " | 232,0 | 12 | 123,0 | 186,0 | 160X1/4 | 3,82 |
| 6" | " | 272,6 | 13 | 148,4 | 222,6 | 190X1/4 | 5,84 |

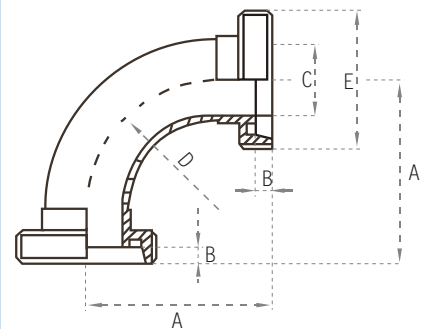
Índice

 Relacionado com os artigos [212D](#) [213D](#)
Curva 90°- polegada OD - macho / niple + porca DIN

bend 90 degree-inch-male/liner DIN

| DN | Art.-Nr. | A | B | C | D | E | G(Kg) |
|-------|----------|-------|-------|-------|-------|---------|-------|
| Rosca | | | | | | | |
| 1" | 456 | 67,1 | 60,1 | 22,4 | 38,1 | 52X1/6 | 0,40 |
| 1½" | " | 90,2 | 82,2 | 35,1 | 57,2 | 65X1/6 | 0,56 |
| 2" | " | 111,2 | 104,2 | 47,8 | 76,2 | 78X1/6 | 0,77 |
| 2½" | " | 135,3 | 127,3 | 59,5 | 95,3 | 95X1/6 | 1,42 |
| 3" | " | 154,3 | 151,3 | 72,2 | 114,3 | 110X1/4 | 1,95 |
| 4" | " | 206,4 | 196,4 | 97,6 | 152,4 | 130X1/4 | 2,67 |
| 5" | " | 232,0 | 220,0 | 123,0 | 186,0 | 160X1/4 | 4,95 |
| 6" | " | 272,6 | 259,6 | 148,4 | 222,6 | 190X1/4 | 7,25 |

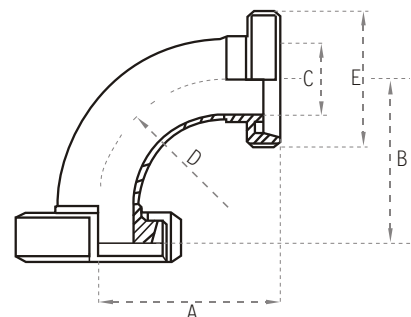

Índice

 Relacionado com os artigos [210](#) [212D](#) [213D](#) [214D](#)

Curva 90° - polegada OD - niple + porca / niple + porca DIN

bend 90 degree-inch-liner/liner DIN

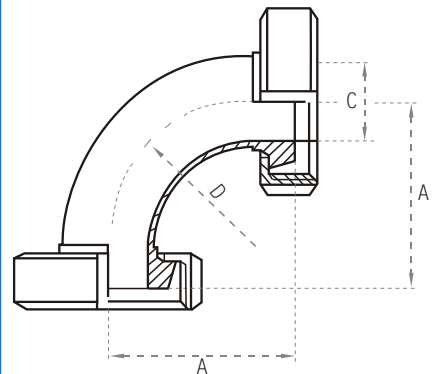
| DN | Art.-Nr. | A | B | C | D | E | G (Kg) |
|-----|----------|-------|---|-------|-------|---|--------|
| 1" | 466 | 60,1 | | 22,4 | 38,1 | | 0,54 |
| 1½" | " | 82,2 | | 35,1 | 57,2 | | 0,76 |
| 2" | " | 104,2 | | 47,8 | 76,2 | | 1,00 |
| 2½" | " | 127,3 | | 59,5 | 95,3 | | 1,84 |
| 3" | " | 151,3 | | 72,2 | 114,3 | | 2,65 |
| 4" | " | 196,4 | | 97,6 | 152,4 | | 4,10 |
| 5" | " | 220,0 | | 123,0 | 186,0 | | 6,08 |
| 6" | " | 259,6 | | 148,4 | 222,6 | | 8,66 |

 Relacionado com os artigos [210](#) [212D](#) [213D](#) [214D](#)
[Índice](#)
Curva 180° - polegada OD - solda

bend 180 degree-inch-welding ends

| DN | Art.-Nr. | A | B | C | D | E | G (Kg) |
|-----|----------|-------|-------|-------|-------|---|--------|
| 1" | 486 | 76,2 | 22,4 | 25,4 | 38,1 | | 0,10 |
| 1½" | " | 114,3 | 35,1 | 38,1 | 57,2 | | 0,23 |
| 2" | " | 152,4 | 47,8 | 50,8 | 76,2 | | 0,24 |
| 2½" | " | 190,5 | 59,5 | 63,5 | 95,2 | | 0,97 |
| 3" | " | 228,6 | 72,2 | 76,2 | 114,3 | | 1,13 |
| 4" | " | 304,8 | 97,6 | 101,6 | 152,4 | | 2,34 |
| 5" | " | 372,0 | 123,0 | 127,0 | 186,0 | | 3,80 |
| 6" | " | 445,2 | 148,4 | 203,2 | 222,6 | | 5,44 |

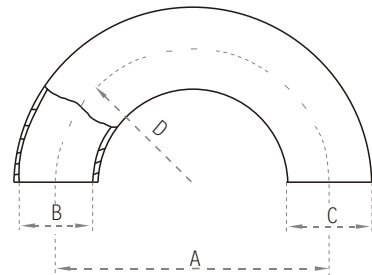
[Índice](#)
Têe reto - polegada OD - solda

tee-inch-welding ends

| DN | Art.-Nr. | A | B | C | D | E | G (Kg) |
|-----|----------|-------|-------|-------|---|---|--------|
| 1" | 5333 K | 38,1 | 22,4 | 25,4 | | | 0,14 |
| 1½" | 5333 K | 57,2 | 35,1 | 38,1 | | | 0,24 |
| 2" | 5333 K | 76,2 | 47,8 | 50,8 | | | 0,33 |
| 2½" | 5333 K | 80,0 | 59,5 | 63,5 | | | 0,69 |
| 3" | 5333 K | 90,0 | 72,2 | 76,2 | | | 0,92 |
| 4" | 5333 K | 100,0 | 97,6 | 101,6 | | | 1,98 |
| 5" | 5333 K | 187,0 | 123,0 | 127,0 | | | 2,71 |
| 6" | 5333 K | 225,0 | 148,4 | 152,4 | | | 3,88 |
| 8" | 5333 K | 300,0 | 199,2 | 203,2 | | | 7,10 |
| 10" | 5333 K | 375,0 | 250,0 | 254,0 | | | 10,96 |

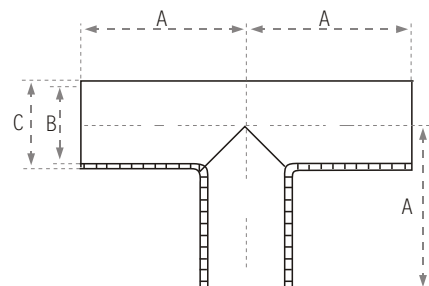
[Índice](#)

Têe reto curto - polegada OD - solda

tee-inch-welding ends-short

| DN | Art.-Nr. | A | B | C | D | E | G(Kg) |
|-----|----------|------|-------|-------|-------|---|-------|
| 1" | 5111 | 38,1 | 22,4 | 25,4 | 17,0 | | 0,10 |
| 1½" | 5111 | 57,2 | 35,1 | 38,1 | 23,0 | | 0,15 |
| 2" | 5111 | 76,2 | 47,8 | 50,8 | 29,5 | | 0,24 |
| 2½" | 5111 | 80 | 59,5 | 63,5 | 36,0 | | 0,46 |
| 3" | 5111 | 90 | 72,2 | 76,2 | 42,0 | | 0,68 |
| 4" | 5111 | 100 | 97,6 | 101,6 | 55,0 | | 0,92 |
| 5" | 5111 | 187 | 123,0 | 127,0 | 74,0 | | 1,97 |
| 6" | 5111 | 225 | 148,4 | 152,4 | 90,0 | | 2,89 |
| 8" | 5111 | 300 | 199,2 | 203,2 | 115,0 | | 5,46 |
| 10" | 5111 | 375 | 250,0 | 254,0 | 140,0 | | 8,43 |

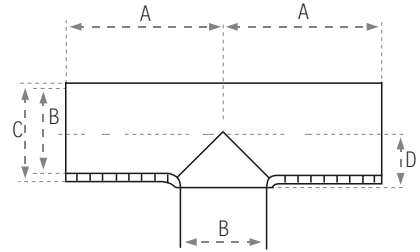
Índice
Têe de redução - polegada OD - solda

tee-inch-welding ends-red.

| DN | Art.-Nr. | A | B | C | D | E | G(Kg) |
|---------|----------|-------|-------|-------|-------|-------|-------|
| 1½"x1" | 5228 | 57,2 | 35,1 | 38,1 | 25,4 | 22,4 | 0,18 |
| 2"x1" | 5228 | 76,2 | 47,8 | 50,8 | 25,4 | 22,4 | 0,27 |
| 2"x1½" | 5228 | 76,2 | 47,8 | 50,8 | 38,1 | 35,1 | 0,31 |
| 2½"x1" | 5228 | 80,0 | 59,5 | 63,5 | 25,4 | 22,4 | 0,50 |
| 2½"x1½" | 5228 | 80,0 | 59,5 | 63,5 | 38,1 | 35,1 | 0,51 |
| 2½"x2" | 5228 | 80,0 | 59,5 | 63,5 | 50,8 | 47,8 | 0,60 |
| 3"x1" | 5228 | 90,0 | 72,2 | 76,2 | 25,4 | 22,4 | 0,73 |
| 3"x1½" | 5228 | 90,0 | 72,2 | 76,2 | 38,1 | 35,1 | 0,74 |
| 3"x2" | 5228 | 90,0 | 72,2 | 76,2 | 50,8 | 47,8 | 0,76 |
| 3"x2½" | 5228 | 90,0 | 72,2 | 76,2 | 63,5 | 59,5 | 0,84 |
| 4"x1" | 5228 | 100,0 | 97,6 | 101,6 | 25,4 | 22,4 | 1,02 |
| 4"x1½" | 5228 | 100,0 | 97,6 | 101,6 | 38,1 | 35,1 | 1,06 |
| 4"x2" | 5228 | 100,0 | 97,6 | 101,6 | 50,8 | 47,8 | 1,08 |
| 4"x2½" | 5228 | 100,0 | 97,6 | 101,6 | 63,5 | 59,5 | 1,17 |
| 4"x3" | 5228 | 100,0 | 97,6 | 101,6 | 76,2 | 72,2 | 1,24 |
| 5"x2" | 5228 | 187,0 | 123,0 | 127,0 | 25,4 | 22,4 | 2,02 |
| 5"x1½" | 5228 | 187,0 | 123,0 | 127,0 | 38,1 | 35,1 | 2,04 |
| 5"x2" | 5228 | 187,0 | 123,0 | 127,0 | 50,8 | 47,8 | 2,07 |
| 5"x2½" | 5228 | 187,0 | 123,0 | 127,0 | 63,5 | 59,5 | 2,08 |
| 5"x3" | 5228 | 187,0 | 123,0 | 127,0 | 76,2 | 72,2 | 2,17 |
| 5"x4" | 5228 | 187,0 | 123,0 | 127,0 | 101,6 | 97,6 | 2,22 |
| 6"x2" | 5228 | 225,0 | 148,4 | 152,4 | 25,4 | 22,4 | 2,98 |
| 6"x1½" | 5228 | 225,0 | 148,4 | 152,4 | 38,1 | 35,1 | 2,99 |
| 6"x2" | 5228 | 225,0 | 148,4 | 152,4 | 50,8 | 47,8 | 3,02 |
| 6vx2½" | 5228 | 225,0 | 148,4 | 152,4 | 63,5 | 59,5 | 3,03 |
| 6"x3" | 5228 | 225,0 | 148,4 | 152,4 | 76,2 | 72,2 | 3,09 |
| 6"x4" | 5228 | 225,0 | 148,4 | 152,4 | 101,6 | 97,6 | 3,18 |
| 6"x5" | 5228 | 225,0 | 148,4 | 152,4 | 127,0 | 123,0 | 3,39 |

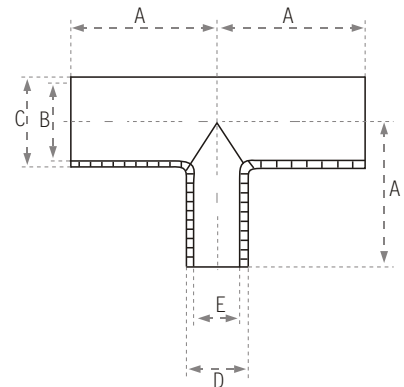
Índice

Têe reto - polegada OD - clamp / clamp / clamp

tee-inch-CCC

| DN | Art.-Nr. | A | B | C | D | E | G (Kg) |
|-----|----------|-------|---|------|---|-------|--------|
| 1" | 5444 | 50,8 | | 22,4 | | 50,5 | 0,31 |
| 1½" | 5444 | 69,9 | | 35,1 | | 50,5 | 0,34 |
| 2" | 5444 | 88,9 | | 47,8 | | 64,0 | 0,50 |
| 2½" | 5444 | 92,7 | | 59,5 | | 91,0 | 0,92 |
| 3" | 5444 | 102,7 | | 72,2 | | 106,0 | 1,45 |
| 4" | 5444 | 112,7 | | 97,6 | | 119,0 | 1,74 |

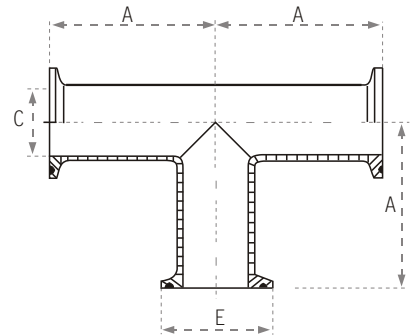
 Relacionado com os artigos **285Z** **288Z**
Índice
Cruzeta - polegada OD - solda

cross-inch-welding ends

| DN | Art.-Nr. | A | B | C | D | E | G (Kg) |
|-----|----------|-------|-------|-------|---|---|--------|
| 1" | 576 | 76,2 | 22,4 | 25,4 | | | 0,11 |
| 1½" | 576 | 114,4 | 35,1 | 38,1 | | | 0,27 |
| 2" | 576 | 152,4 | 47,8 | 50,8 | | | 0,34 |
| 2½" | 576 | 160,0 | 59,5 | 63,5 | | | 0,78 |
| 3" | 576 | 180,0 | 72,2 | 76,2 | | | 1,02 |
| 4" | 576 | 200,0 | 97,6 | 101,6 | | | 2,32 |
| 5" | 576 | 374,0 | 123,0 | 127,0 | | | 3,45 |
| 6" | 576 | 450,0 | 148,4 | 152,4 | | | 4,87 |
| 8" | 576 | 600,0 | 199,2 | 203,2 | | | 8,74 |
| 10" | 576 | 750,0 | 250,0 | 254,0 | | | 13,49 |

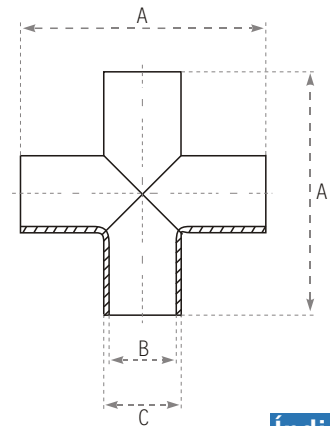
Índice
Têe 45° - polegada OD - solda

tee 45° inch-welding ends

| DN | Art.-Nr. | A | B | C | D | E | G (Kg) |
|-----|----------|-------|-------|------|-------|------|--------|
| 1" | 572 | 152,4 | 123,0 | 20,5 | 115,5 | 28,2 | 0,10 |
| 1½" | 572 | 187,3 | 150,0 | 22,5 | 143,6 | 32,5 | 0,21 |
| 2" | 572 | 222,2 | 171,0 | 31,0 | 171,3 | 35,0 | 0,29 |
| 2½" | 572 | 254,0 | 203,0 | 25,0 | 206,7 | 40,9 | 0,62 |
| 3" | 572 | 273,0 | 210,0 | 32,0 | 224,3 | 39,1 | 0,85 |
| 4" | 572 | 325,4 | 252,0 | 44,1 | 279,6 | 44,1 | 1,62 |

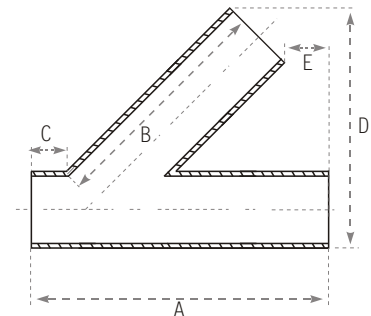
Índice

Têe curva - polegada OD - solda

tee bend-inch-welding ends

| DN | Art.-Nr. | A | B | C | D | E | G (Kg) |
|-----|----------|-------|------|-------|-------|---|--------|
| 1" | 574 | 38,1 | 22,4 | 25,4 | 38,1 | | 0,10 |
| 1½" | 574 | 57,2 | 35,1 | 38,1 | 57,2 | | 0,21 |
| 2" | 574 | 76,2 | 47,8 | 50,8 | 76,2 | | 0,29 |
| 2½" | 574 | 95,2 | 59,5 | 63,5 | 95,2 | | 0,62 |
| 3" | 574 | 114,3 | 72,2 | 76,2 | 114,3 | | 0,85 |
| 4" | 574 | 152,4 | 97,6 | 101,6 | 152,4 | | 1,62 |

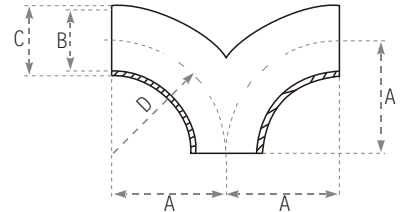
Índice
Ponteira p/ mangueira - polegada OD

hose nozzle-inch tube

| DN | Art.-Nr. | A | B | C | D | E | G (Kg) |
|-----|----------|-----|----|----|-------|---|--------|
| 1" | 239 Z | 60 | 35 | 15 | 25,4 | | 0,04 |
| 1½" | 239 Z | 80 | 45 | 20 | 38,1 | | 0,09 |
| 2" | 239 Z | 90 | 45 | 20 | 50,8 | | 0,13 |
| 2½" | 239 Z | 100 | 50 | 25 | 63,5 | | 0,42 |
| 3" | 239 Z | 110 | 55 | 25 | 76,1 | | 0,50 |
| 4" | 239 Z | 120 | 65 | 25 | 101,6 | | 0,58 |

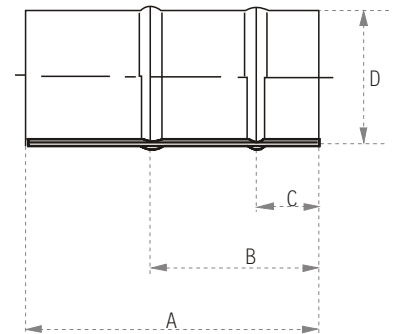
Índice
Abraçadeira p/ mangueira

hose clip

| DN | Art.-Nr. | A | B | C | D | E | G (Kg) |
|-------|----------|---|---|---|---|---|--------|
| | Diâmetro | | | | | | |
| 239 S | 12-20 | | | | | | 0,02 |
| 239 S | 16-25 | | | | | | 0,02 |
| 239 S | 20-32 | | | | | | 0,02 |
| 239 S | 25-40 | | | | | | 0,02 |
| 239 S | 32-50 | | | | | | 0,03 |
| 239 S | 40-60 | | | | | | 0,03 |
| 239 S | 50-70 | | | | | | 0,03 |
| 239 S | 60-80 | | | | | | 0,04 |
| 239 S | 70-90 | | | | | | 0,04 |
| 239 S | 80-100 | | | | | | 0,04 |
| 239 S | 90-110 | | | | | | 0,04 |
| 239 S | 100-120 | | | | | | 0,05 |

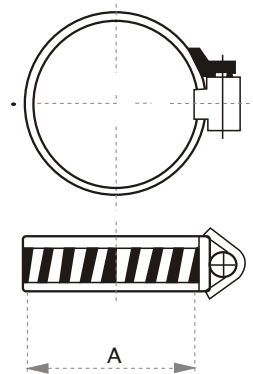
Índice